

ULTRA THIN FAN FILTER UNIT (PFT2 series)

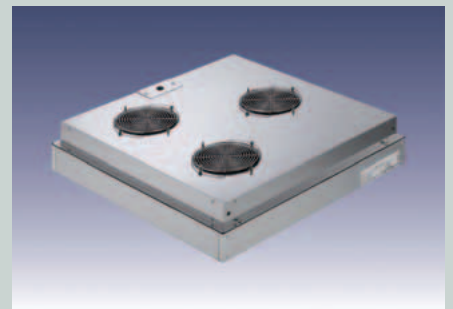
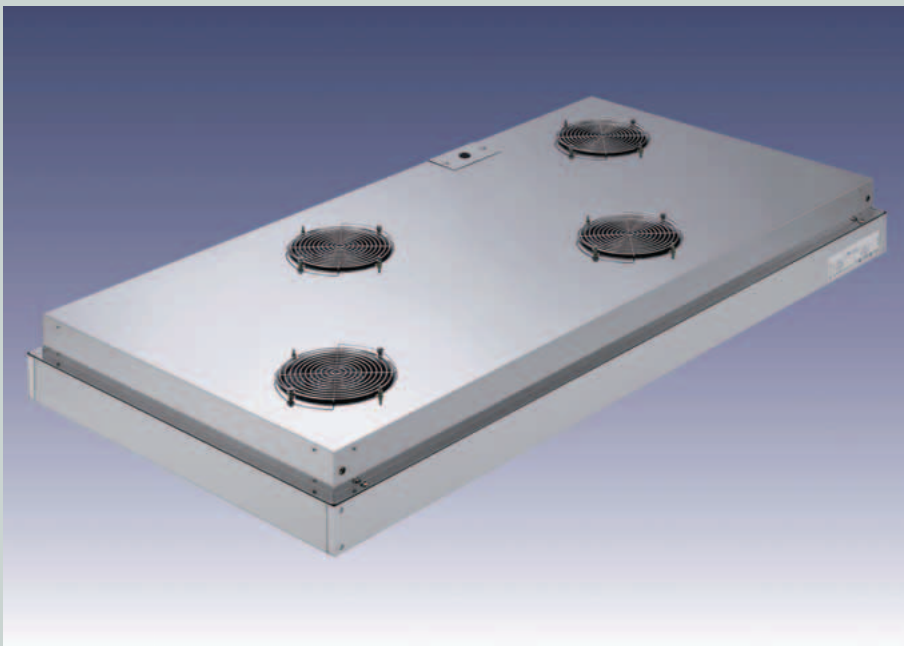

It's thin and light weight multipurpose unit and also easy to install and make the limited area cleanly purified.

Various module sizes, filter grade and electric power. It can meet the requirements on various applications.

Features

Thin and Light Weight

- The thickness of the unit is 145mm. It's one of the thinnest in the industry.
- It's so light, only approx.12kgs for the module with 610mm.

Abundant Variation

- The module size is available for 250x250 up to 610x1220.
- Filters are available for HEPA, ULPA and Ultra ULPA.
(and also available for medium and chemical filter use)
- DC12V,24V,48V are also available in addition to AC100V.
(single phase), AC200V(single phase), AC200V(3 phases)

Applications

- Semiconductor/LCD
- Food industry
- Equipments for physics and chemistry
- Hospital / Medical Facilities
- Pharmaceutical Industry etc.

Model No.

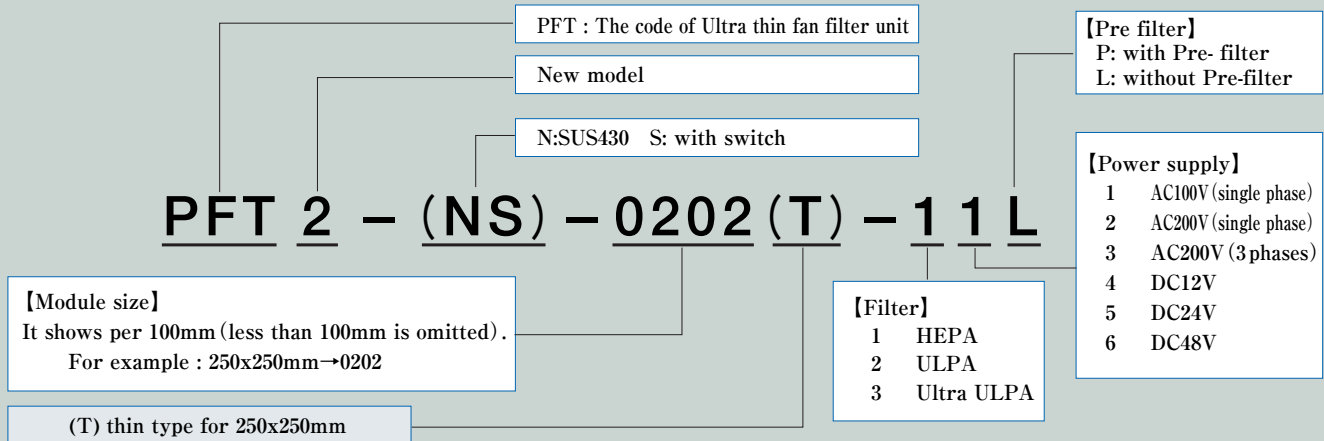

Specifications

Remarks

1. Air volume value in parenthesis () is for the model with Pre-filter. Left: 50Hz, Right: 60Hz
2. Air volume value for the use with DC is the same as AC with 50Hz
3. AC200V(3phases) is not available for the 1st item 250x250 module(T) thin type
4. The unit with switch is available only for AC100V (single phase), AC200V (single phase), DC12V, 24V
5. Controller of air volume are available only for AC100V (single phase), AC200V (single phase), DC48V

No.	item	250×250 module (thin type)		
1	model	PFT2-N-0202T-1**	PFT2-N-0202T-2**	PFT2-N-0202T-3**
2	external size (mm)	250×250×130		
3	casing	SUS430		
4	fan	axial fan 1pce		
5	filter	HEPA	ULPA	Ultra ULPA
6	air volume (m ³ /min) left:50Hz/ right:60Hz	0.9/1.1 (0.8/1.0)	0.8/1.0 (0.7/0.9)	0.7/0.9 (0.7/0.8)
7	collection efficiency (%)	99.99 (0.3μm)	99.999 (0.1~0.15μm)	99.9999 (0.1~0.15μm)
8	power supply	available with AC100V (single phase), AC200V (single phase), DC12, 24, 48V		
9	power consumption (W)	AC: 15/13, DC: 10		
10	weight (kg)	approx.3.5		

No.	item	250×250 module		
1	model	PFT2-N-0202-1**	PFT2-N-0202-2**	PFT2-N-0202-3**
2	external size (mm)	250×250×145		
3	casing	SUS430		
4	fan	axial fan 1pce		
5	filter	HEPA	ULPA	Ultra ULPA
6	air volume (m ³ /min) left:50Hz/ right:60Hz	1.7/2.2 (1.6/2.0)	1.6/2.1 (1.5/1.9)	1.5/2.0 (1.4/1.8)
7	collection efficiency (%)	99.99 (0.3μm)	99.999 (0.1~0.15μm)	99.9999 (0.1~0.15μm)
8	power supply	available with AC100V (single phase), AC200V (single phase), AC200V (3 phases), DC12, 24, 48V		
9	power consumption (W)	AC: 34/32, DC: 19		
10	weight (kg)	approx.4.0		

No.	item	400×400 module		
1	model	PFT2-N-0404-1**	PFT2-N-0404-2**	PFT2-N-0404-3**
2	external size (mm)	400×400×145		
3	casing	SUS430		
4	fan	axial fan 1pce		
5	filter	HEPA	ULPA	Ultra ULPA
6	air volume (m ³ /min) left:50Hz/ right:60Hz	3.5/4.5 (3.0/4.1)	3.1/4.2 (2.5/3.6)	2.6/3.7 (2.4/3.2)
7	collection efficiency (%)	99.99 (0.3μm)	99.999 (0.1~0.15μm)	99.9999 (0.1~0.15μm)
8	power supply	available with AC100V (single phase), AC200V (single phase), AC200V (3 phases), DC12, 24, 48V		
9	power consumption (W)	AC: 34/32, DC: 19		
10	weight (kg)	approx.6.0		

Specifications

No.	item	500×500 module		
1	model	PFT2-N-0505-1**	PFT2-N-0505-2**	PFT2-N-0505-3**
2	external size (mm)	500×500×145		
3	composition	casing	SUS430	
4		fan	axial fan 2pcs	
5		filter	HEPA	ULPA
6	air volume (m ³ /min) left:50Hz/ right:60Hz	6.0/8.0 (5.0/7.2)	5.1/7.4 (4.7/6.4)	4.7/6.4 (4.5/5.7)
7	collection efficiency (%)	99.99 (0.3μm)	99.999 (0.1~0.15μm)	99.9999 (0.1~0.15μm)
8	power supply	available with AC100V (single phase), AC200V (single phase), AC200V (3 phases), DC12, 24, 48V		
9	power consumption (W)	AC: 68/64, DC: 38		
10	weight (kg)	approx.9.0		

No.	item	610×610 module		
1	model	PFT2-N-0606-1**	PFT2-N-0606-2**	PFT2-N-0606-3**
2	external size (mm)	610×610×145		
3	composition	casing	SUS430	
4		fan	axial fan 3pcs	
5		filter	HEPA	ULPA
6	air volume (m ³ /min) left:50Hz/ right:60Hz	10.0/12.8 (7.8/11.2)	7.6/9.9 (7.3/9.8)	7.3/9.8 (6.7/8.7)
7	collection efficiency (%)	99.99 (0.3μm)	99.999 (0.1~0.15μm)	99.9999 (0.1~0.15μm)
8	power supply	available with AC100V (single phase), AC200V (single phase), AC200V (3 phases), DC12, 24, 48V		
9	power consumption (W)	AC: 102/96, DC: 57		
10	weight (kg)	approx.12.0		

No.	item	610×760 module		
1	model	PFT2-N-0607-1**	PFT2-N-0607-2**	PFT2-N-0607-3**
2	external size (mm)	610×760×145		
3	composition	casing	SUS430	
4		fan	axial fan 3pcs	
5		filter	HEPA	ULPA
6	air volume (m ³ /min) left:50Hz/ right:60Hz	10.7/13.7 (8.6/12.3)	9.6/12.8 (7.9/11.4)	7.9/11.4 (7.2/9.6)
7	collection efficiency (%)	99.99 (0.3μm)	99.999 (0.1~0.15μm)	99.9999 (0.1~0.15μm)
8	power supply	available with AC100V (single phase), AC200V (single phase), AC200V (3 phases), DC12, 24, 48V		
9	power consumption (W)	AC: 102/96, DC: 57		
10	weight (kg)	approx.14.0		

No.	item	610×915 module		
1	model	PFT2-N-0609-1**	PFT2-N-0609-2**	PFT2-N-0609-3**
2	external size (mm)	610×915×145		
3	composition	casing	SUS430	
4		fan	axial fan 3pcs	
5		filter	HEPA	ULPA
6	air volume (m ³ /min) left:50Hz/ right:60Hz	11.6/14.5 (10.4/13.0)	10.6/13.6 (9.0/12.4)	9.9/12.8 (7.8/11.5)
7	collection efficiency (%)	99.99 (0.3μm)	99.999 (0.1~0.15μm)	99.9999 (0.1~0.15μm)
8	power supply	available with AC100V (single phase), AC200V (single phase), AC200V (3 phases), DC12, 24, 48V		
9	power consumption (W)	AC: 102/96, DC: 57		
10	weight (kg)	approx.15.5		

No.	item	610×1220 module		
1	model	PFT2-N-0612-1**	PFT2-N-0612-2**	PFT2-N-0612-3**
2	external size (mm)	610×1220×145		
3	composition	casing	SUS430	
4		fan	axial fan 3pcs	
5		filter	HEPA	ULPA
6	air volume (m ³ /min) left:50Hz/ right:60Hz	15.5/20.0 (13.7/17.6)	14.3/18.2 (12.0/16.4)	13.3/17.1 (10.7/15.3)
7	collection efficiency (%)	99.99 (0.3μm)	99.999 (0.1~0.15μm)	99.9999 (0.1~0.15μm)
8	power supply	available with AC100V (single phase), AC200V (single phase), AC200V (3 phases), DC12, 24, 48V		
9	power consumption (W)	AC: 136/128, DC: 76		
10	weight (kg)	approx.20.0		

Product Outline

PFT2-N-0606-***

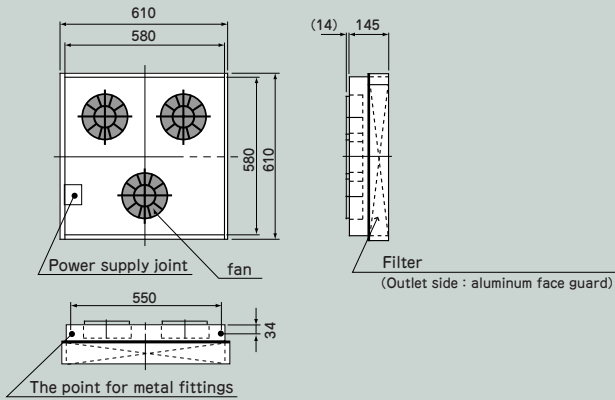

PFT2-N-0612-***

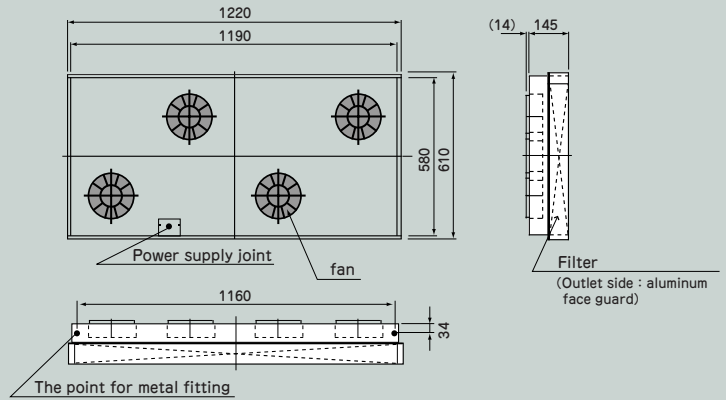

Applications

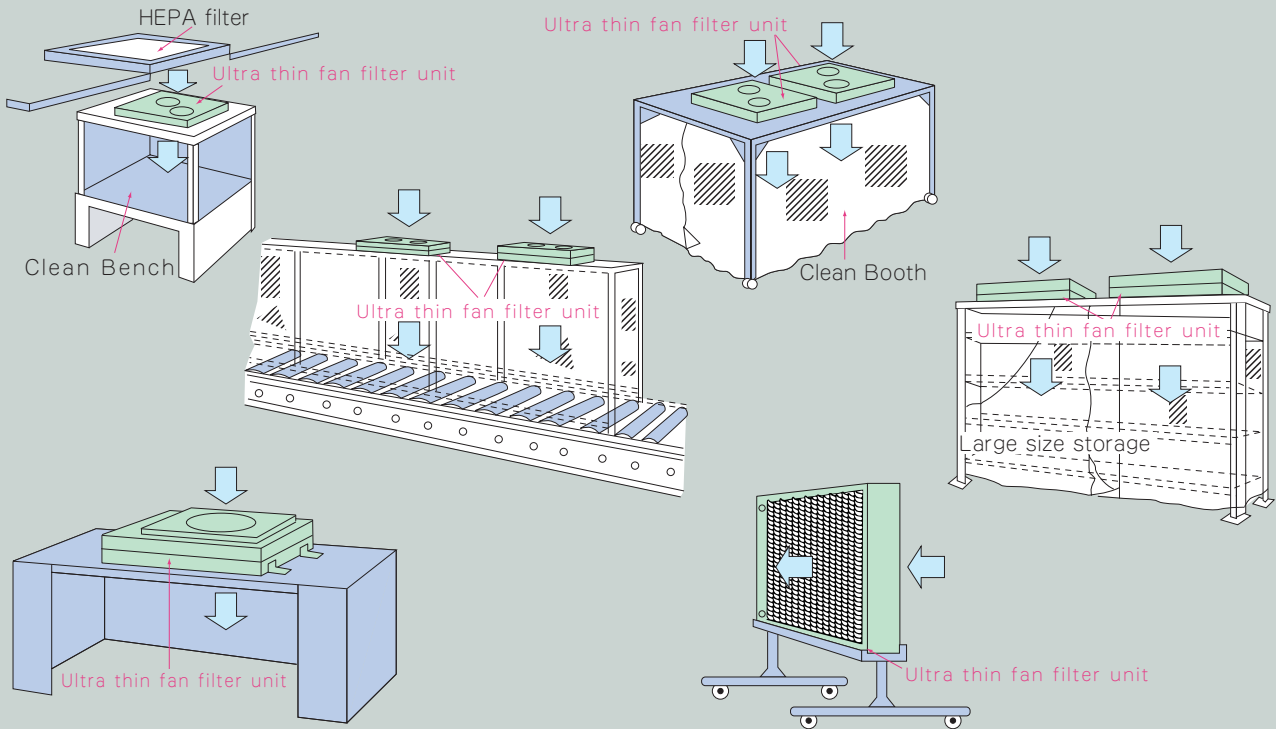

This catalog is subject to change without any prior notice.

 NIPPON MUKI CO., LTD.

- Head Office Kokubu Bldg., 1-1-1 Nihonbashi, Chuo-ku, Tokyo, 103-0027 Japan
- Tohoku Office Sompo Japan Sendai KY Bldg., 3-10-19 Chuo, Aoba-ku, Sendai, Miyagi 980-0021 Japan
- Osaka Office Sumitomo Bldg., 4-5-33 Kitahama, Chuo-ku, Osaka 541-0041 Japan
- Chubu Office Seifu Bldg., 3-21-25 Marunouchi, Naka-ku, Nagoya, Aichi 460-0002 Japan
- Kyushu Office Solon Akasaka Bldg., 1-9-33 Daimyo, Chuo-ku, Fukuoka 810-0041 Japan
- Hiroshima Office Nomura Fudousan Otemachi Bldg., 2-8-5 Otemachi, Naka-ku, Hiroshima 730-0051 Japan
- NIPPON MUKI (SHANGHAI) CO.,LTD. Room 6406, Business Center, Rui Jin Guest House, 118 Rui Jin 2 Road, Shanghai 200020 China

- Tel. +81-3-5290-5902
- Tel. +81-22-266-7531
- Tel. +81-6-6201-3751
- Tel. +81-52-957-5900
- Tel. +81-92-715-1651
- Tel. +81-82-248-3920
- Tel. +86-21-6445-0176